

ANSI/IEEE Std 390-1987

(Revision of ANSI/IEEE Std 390-1975 and IEEE Std 391-1976)

An American National Standard

IEEE Standard for Pulse Transformers

Sponsor

**Electronics Transformer Technical Committee
of the
IEEE Magnetics Society**

Approved December 11, 1986

IEEE Standards Board

Approved May 18, 1987

American National Standards Institute

©Copyright 1987 by

The Institute of Electrical and Electronics Engineers, Inc 345 East 47th Street, New York, NY 10017, USA

No part of this publication may be reproduced in any form, in an electronic retrieval system or otherwise, without the prior written permission of the publisher.

IEEE Standards documents are developed within the Technical Committees of the IEEE Societies and the Standards Coordinating Committees of the IEEE Standards Board. Members of the committees serve voluntarily and without compensation. They are not necessarily members of the Institute. The standards developed within IEEE represent a consensus of the broad expertise on the subject within the Institute as well as those activities outside of IEEE which have expressed an interest in participating in the development of the standard.

Use of an IEEE Standard is wholly voluntary. The existence of an IEEE Standard does not imply that there are no other ways to produce, test, measure, purchase, market, or provide other goods and services related to the scope of the IEEE Standard. Furthermore, the viewpoint expressed at the time a standard is approved and issued is subject to change brought about through developments in the state of the art and comments received from users of the standard. Every IEEE Standard is subjected to review at least once every five years for revision or reaffirmation. When a document is more than five years old, and has not been reaffirmed, it is reasonable to conclude that its contents, although still of some value, do not wholly reflect the present state of the art. Users are cautioned to check to determine that they have the latest edition of any IEEE Standard.

Comments for revision of IEEE Standards are welcome from any interested party, regardless of membership affiliation with IEEE. Suggestions for changes in documents should be in the form of a proposed change of text, together with appropriate supporting comments.

Interpretations: Occasionally questions may arise regarding the meaning of portions of standards as they relate to specific applications. When the need for interpretations is brought to the attention of IEEE, the Institute will initiate action to prepare appropriate responses. Since IEEE Standards represent a consensus of all concerned interests, it is important to ensure that any interpretation has also received the concurrence of a balance of interests. For this reason IEEE and the members of its technical committees are not able to provide an instant response to interpretation requests except in those cases where the matter has previously received formal consideration.

Comments on standards and requests for interpretations should be addressed to:

Secretary, IEEE Standards Board
345 East 47th Street
New York, NY 10017
USA

Foreword

(This Foreword is not a part of ANSI/IEEE Std 390-1987, IEEE Standard for Pulse Transformers.)

The purpose of this standard is to provide a common ground between electronic system engineers and pulse transformer design engineers.

This standard does not apply to transformers when used in a wire entrance facility to an electric power station. Neither is it intended to include low-power *switching-type* pulse transformers. These are covered in IEEE Std 272 1970, IEEE Standard for Computer-Type (Square-Loop) Pulse Transformers.

This standard pertains to pulse transformers that transmit peak power that averages from a few milliwatts to those that transmit peak power that averages in the kilowatts. Also, the voltage range is from a few peak volts to many peak kilovolts.

Initially, the impetus for developing pulse transformers of all types, came from the need for these devices in the radar used in World War II. The range of voltage and power of these types of transformers is still being increased as magnetrons, klystrons, and traveling wave and cross-field amplifier loads are developed for higher voltage and power. It is hoped that this standard will benefit the manufacturer and the user of these transformers.

This standard is a combination of two original standards: ANSI/IEEE Std 390-1975 and IEEE Std 391-1976. IEEE Std 391-1976 has been simultaneously withdrawn with the publication of this revision of ANSI/IEEE Std 390-1987. This standard was prepared under the Subcommittee Chairmanships of J. D. Schwartz and A. A. Toppeto, respectively, and the Working Group Chairmanships of W J. Field and A. D. Hasley, respectively.

At the time this standard was approved the membership of the Working Group of the Pulse Transformer Subcommittee was as follows:

E. D. Belanger, Chair

Michael I. Distefano
John B. Evans

A. D. Hasley
R. M. Rowe
J. D. Schwartz

John Tardy
Herman I. Tillinger

At the time this standard was approved the membership of the Pulse Transformer Technical Committee of the IEEE Magnetics Society was as follows:

A. A. Toppeto, Chair

Jack Adams
P. A. Cattermole
Richard P. Carey
David E. Cavenaugh
Michael I. Distefano
John B. Evans
W. J. Field
Russell Fischer

A. D. Hasley
Reuben Lee
Dale Leppert
W. A. Martin
Bernie McDonnell
H. S. Mitsanas
D. D. Meacham
Cyril Pouch
R. M. Rowe

Eugene Shaeffer
J. D. Schwartz
Mark E. Shepard
John Tardy
Herman I. Tillinger
L. E. Unnewehr
Larry W. Vann
R. G. Wolpert

The following persons were on the balloting committee that approved this document for submission to the IEEE Standards Board.

E. D. Belanger
Richard P. Carey
Michael I. Distefano
C. J. Elliott
H. Fickensher
Russell Fischer

R. A. Frantz
P Goethe
L. W. Kirkwood
H. Lee
R. Lee
H. W. Lord

O. Kiltie
R. L. Sell
John Tardy
Herman I. Tillinger
J. P. Whistler
R. G. Wolpert

When the IEEE Standards Board approved this standard on December 11, 1986, it had the following membership:

John E. May, *Chair*
Irving Kolodny, *Vice Chair*
Sava I. Sherr, *Secretary*

James H. Beall
Fletcher J. Buckley
Paul G. Cummings
Donald C. Fleckenstein
Jay Forster
Daniel L. Goldberg
Kenneth D. Hendrix
Irvin N. Howell

Jack Kinn
Joseph L. Koepfinger*
Edward Lohse
Lawrence V. McCall
Donald T. Michael*
Marco W. Migliaro
Stanley Owens
John P. Riganati
Frank L. Rose

Robert E. Rountree
Martha Sloan
Oley Wanaselja
J. Richard Weger
William B. Wilkens
Helen M. Wood
Charles J. Wylie
Donald W. Zipse

*Member emeritus

CLAUSE	PAGE
1. Scope and References	1
1.1 Scope	1
1.2 References	1
1.3 Typical Transformer Types to which this Standard Applies	2
1.4 Related Transformer Standards	2
2. Definitions	2
3. Symbols	5
3.1 Pulse Transformer Schematics	5
3.2 Input Pulse—Source Voltage Pulse Applied Through Associated Impedance or Source Current Pulse ..	5
3.3 Output Pulse—Transformed Voltage Pulse or Load Current Pulse	6
3.4 Source and Load Impedance	6
3.5 Transformer Parameters	6
4. Performance Tests	7
4.1 Electric Strength	7
4.2 Induced Voltage Electric Strength	8
4.3 Direct-Current Insulation Resistance	8
4.4 Ratio of Transformation (Turns Ratio)	9
4.5 Polarity	9
4.6 Direct-Current Resistance of Windings Referred to 25 °C	9
4.7 Short-Circuit Impedance (Leakage Inductance)	9
4.8 Open-Circuit Parameters (Magnetizing Pulse Inductance and Exciting Current)	10
4.9 Open-Circuit Admittance (Distributed Capacitance)	10
4.10 Voltage-Time Product Rating	11
4.11 Direct Capacitance Between Windings	11
4.12 Balance	11
4.13 Functional Test	11
4.14 Corona (Partial Discharge) Tests	13
4.15 Temperature Rise Test	13
5. Equivalent Circuits	13
5.1 <i>Complete</i> Equivalent Circuit for a Pulse Transformer	13
5.2 <i>Partial</i> Equivalent Circuits for a Pulse Transformer	15
5.3 Pulse Transformer Tests to Determine Equivalent Circuit Elements	20
5.4 Pulse Response Parameters Under Load	21
6. Preferred Test Methods	21
6.1 Ratio of Transformation (Turns Ratio) Test Method (See 4.4)	21
6.2 Short-Circuit Impedance (Leakage Inductance) Test Method (See 4.7)	22
6.3 Open-Circuit Admittance (Distributed Capacitance) Test Methods (See 4.9)	23
6.4 Open-Circuit Impedance (Magnetizing Pulse Inductance and Exciting Current) Test Method. Recommended Method: Rectangular Voltage Pulse Applied from Low-Impedance Source, and Pulse-Exciting Current Response Observed (See 4.8)	23

CLAUSE	PAGE
6.5 Voltage-Time Product Test Method. Recommended Methods: Rectangular Voltage Pulse Applied from Low-Impedance Source and Pulse-Exciting Current Response Observed (See 4.10)	26
6.6 Three Recommended Balance Test Methods (See 4.12)	27
6.7 Temperature Rise Test (See 4.15).....	28
6.8 Corona (Partial Discharge) Test (See 4.14)	30
7. Marking	30
8. Service Conditions	31
9. Bibliography.....	31
Annex A Alternate Test Methods (Informative).....	32

An American National Standard

IEEE Standard for Pulse Transformers

1. Scope and References

1.1 Scope

This standard pertains to pulse transformers for use in electronic equipment. For the various types of these transformers, the peak power transmitted ranges from a few milliwatts to kilowatts; and the peak voltage transmitted ranges from a few volts to many kilovolts.

These transformers are required to transmit unipolar or bipolar pulses of voltage or current within specified tolerances of amplitude and time when operated between specified impedances. They are typically used as coupling devices in electronic circuits. In blocking oscillators, they are connected to provide positive feedback in the circuit. In radar or similar use, they are used to couple the modulator to a magnetron, a klystron, a traveling-wave tube or a cross-field amplifier load.

Whenever numerical values are indicated in this standard, they may be considered as recommended values. Section 6. describes the preferred transformer test methods and Appendix A contains alternate test methods.

1.2 References

This standard shall be used in conjunction with the following publications:

[1] ANSI/IEEE Std 100-1984, IEEE Standard Dictionary of Electrical and Electronics Terms.¹

[2] ANSI/IEEE Std 111-1984, IEEE Standard for Wide-Band Transformers.

[3] ANSI/IEEE Std 260-1978 (R 1985), IEEE Standard Letter Symbols for Units of Measurement (SI Units, Customary Inch-Pound Units and Certain Other Units).

[4] ANSI/IEEE Std 268-1982, American National Standard for Metric Practice.

[5] ANSI/IEEE Std 280-1985, IEEE Standard Letter Symbols for Quantities Used in Electrical Science and Electrical Engineering.

[6] ANSI/IEEE Std 315-1975 (CSA Z99-1975), IEEE Graphic Symbols for Electrical and Electronics Diagrams.

[7] ANSI/IEEE Std 315A-1986, IEEE Standard—Supplement to Graphic Symbols for Electrical and Electronics Diagrams.

¹ANSI/IEEE publications can be obtained from the Sales Department, American National Standards Institute, 1430 Broadway, New York, NY 10018, or from the Service Center, The Institute of Electrical and Electronics Engineers, 445 Hoes Lane, PO Box 1331, Piscataway, NJ 08855-1331.

[8] ANSI/IEEE Std 455-1985, IEEE Standard Test Procedure for Measuring Longitudinal Balance of Telephone Equipment Operating in the Voice Band.

[9] IEEE Std 119-1974, IEEE Recommended Practice for General Principles of Temperature Measurement as Applied to Electrical Apparatus.

[10] IEEE Std 194-1977, IEEE Standard Pulse Terms and Definitions.

[11] IEEE Std 272-1970 (R 1976), IEEE Standard for Computer-Type (Square-Loop) Pulse Transformers.

[12] IEEE Std 389-1979, IEEE Recommended Practice for Testing Electronics Transformers and Inductors.

[13] HENRY, D. A. and TOPPETO, A. A. Pulse Inductance — Problems and Peculiarities. *Electronic Components Conference*, 1972.

[14] MUNK, P. R. and SARTORI, E. F. A Theoretical and Experimental Study of Transformer Balance. *IEEE Transactions on Parts, Materials, and Packaging*, vol PMP-4, no 1, March 1968, pp 12–21.

1.3 Typical Transformer Types to which this Standard Applies

This standard applies to the following transformer types:

- 1) Power output (drivers)
- 2) Impedance matching
- 3) Interstage coupling
- 4) Current sensing
- 5) Blocking-oscillator transformers

1.4 Related Transformer Standards

ANSI/IEEE Std 111-1984, IEEE Standard for Wide-Band Transformers.

IEEE Std 266-1969 (R 1981), IEEE Test Procedure for Evaluation of Insulation Systems for Electronics Power Transformers.

IEEE Std 272-1970 (R 1976), IEEE Standard for Computer-Type (Square-Loop) Pulse Transformers.

IEEE Std 306-1969 (R 1981), IEEE Test Procedure for Charging Inductors.

RS 176-1956, Pulse Transformers for Radar Equipment.²

RS 181-1957, Iron Core Charging Inductors.

2. Definitions

Electrical terms used in this standard shall be in accordance with those given in IEEE Std 194-1977 [10]³ and ANSI/IEEE Std 100-1984 [1]. In addition, a number of terms are defined in this section; however, ANSI/IEEE Std 100-1984 [1] shall take precedence in the case of any conflict.

²These publications can be obtained from the Sales Department, Electronic Industries Association, 2001 Eye St NW, Washington, DC 20006.

³The numbers in brackets correspond to those of the references in 1.2.

2.1 peak working voltage: The maximum instantaneous voltage stress that may appear under operation across the insulation being considered, including abnormal and transient conditions.

2.2 input pulse shape: Current pulse or source voltage pulse applied through associated impedance. The shape of the input pulse is described by a current- or voltage-time relationship and is defined with the aid of Fig 1 in accordance with the following definitions.

NOTE — A general amplitude quantity is designated by A , which may be current I or voltage V

2.2.1 pulse amplitude, A_M : That quantity determined by the intersection of a line passing through the points on the leading edge where the instantaneous value reaches 10% and 90% of A_M and a straight line that is the best least-squares fit to the pulse in the pulse-top region (usually this is fitted visually rather than numerically). For pulses deviating greatly from the ideal trapezoidal pulse shape, a number of successive approximations may be necessary to determine A_M .

NOTE — The pulse amplitude A_M may be arrived at by applying the following procedure.

Step 1: Visually or numerically determine the best straight line fit to the pulse in the pulse-top region and extend this straight line into the leading-edge region.

Step 2: An initial estimate of A_M is the first intersection of the pulse (in the late leading-edge or early pulse-top regions) with the straight line fitted to the pulse top.

Step 3: Using the estimated of A_M calculate $0.1 A_M$ and $0.9 A_M$ and draw a straight line through these two points of the pulse-leading edge.

Step 4: The intersection of the leading-edge straight line and the pulse top straight line gives an improved estimate of A_M

Step 5: Repeat Steps 3 and 4 until the estimate of A_M does not change. The converged estimate is the pulse amplitude A_M

2.2.2 rise time (first transition duration), t_r : The time interval of the leading edge between the instants at which the instantaneous value first reaches the specified lower and upper limits of 10% and 90% of A_M . Limits. Other than 10% and 90% may be specified in special cases.

2.2.3 pulse duration (90%), t_p : The time interval between the instants at which the instantaneous value reaches 90% of A_M on the leading edge and 90% of A_T on the trailing edge.

NOTES:

1 — Often the input pulse tilt (droop) is only a few percentages, and in those cases pulse duration may be considered as the time interval between the first and last instants at which the instantaneous value reaches 90% of A_M

2 — Pulse duration may be specified at a value other than 90% A_M and A_T in special cases.

2.2.4 fall time (last transition duration), t_f : The time interval of the pulse trailing edge between the instants at which the instantaneous value first reaches specified upper and lower limits of 90% and 10% of A_T .

2.2.5 trailing edge (last transition) amplitude, A_T : That quantity determined by the intersection of a line passing through the points on the trailing edge where the instantaneous value reaches 90% and 10% of A_T , and the straight-line segment fitted to the top of the pulse in determining A_M .

2.2.6 tilt (droop), A_D : The difference between A_M and A_T . It is expressed in amplitude units or in percentage of A_M .

2.2.7 overshoot (first transition overshoot), A_{os} : The amount by which the first maximum occurring in the pulse-top region exceeds the straight-line segment fitted to the top of the pulse in determining A_M . It is expressed in amplitude units or as a percentage of A_M .

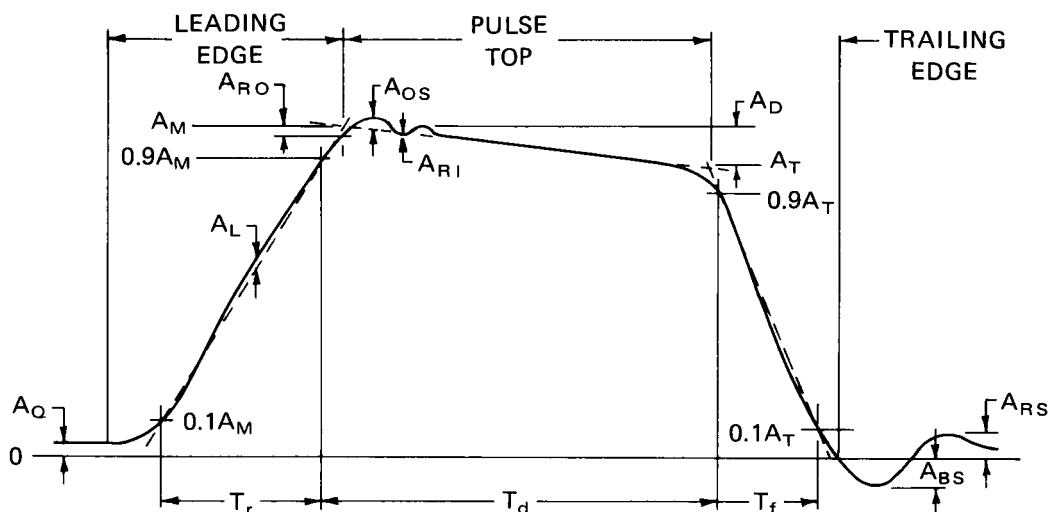

Figure 1—Input Pulse Shape

2.2.8 backswing (last transition overshoot), A_{BS} : The maximum amount by which the instantaneous pulse value is below the zero axis in the region following the fall time. It is expressed in amplitude units or as a percentage of A_M .

2.2.9 return swing (last transition ringing), A_{RS} : The maximum amount by which the instantaneous pulse value is below the zero axis in the region following the backswing. It is expressed in amplitude units or as a percentage of A_M .

2.2.10 rolloff (rounding after first transition), A_{RO} : The amount by which the instantaneous pulse value is less than A_M at the point in time of the intersection of straight-line segments used to determine A_M . It is expressed in amplitude units or as a percentage of A_M .

2.2.11 ringing (first transition ringing), A_{RI} : The maximum amount by which the instantaneous pulse value deviates from the straight-line segment fitted to the top of the pulse in determining A_M in the pulse top region following rolloff, or overshoot, or both. It is expressed in amplitude units or as a percentage of A_M .

2.2.12 leading edge (first transition) linearity, A_L : The maximum amount by which the instantaneous pulse value deviates during the rise time interval from a straight line intersecting the 10% and 90% A_M amplitude points used in determining rise time. It is expressed in amplitude units or as a percentage of $0.8 A_M$.

2.2.13 quiescent value (base magnitude), A_Q : The maximum value existing between pulses.

2.2.14 leading edge (first transition): That portion of the pulse occurring between the time the instantaneous value first becomes greater than A_Q to the time of the intersection of straight-line segments used to determine A_M .

2.2.15 pulse top: That portion of the pulse occurring between the time of intersection of straight-line segments used to determine A_M and A_T .

2.2.16 trailing edge (last transition): That portion of the pulse occurring between the time of intersection of straight-line segments used to determine A_T and the time at which the instantaneous value reduces to zero.

2.3 output pulse shape: Load current pulse flowing in a winding or voltage pulse developed across a winding in response to application of an input pulse. The shape of the output pulse is described by a current- or voltage-time relationship. All of the preceding definitions of 2.2 for the **input pulse shape** apply to the **output pulse shape**. Typically, a prominent feature of the output pulse is an accentuated backswing (last transition overshoot), A_{BS} .

2.4 voltage-time product: The time integral of a voltage pulse applied to a transformer winding.

2.5 voltage-time product rating (of a transformer winding): Considered as being a constant and is the maximum voltage-time product of a voltage pulse that can be applied to the winding before a specified level of core saturation-region effects is reached. The level of core saturation-region effects is determined by observing either the shape of the output voltage pulse for a specified degradation (for example, a maximum tilt [droop]), or the shape of the exciting current pulse for a specified departure from linearity (for example, deviation from a linear ramp by a given percentage).

3. Symbols

Except where otherwise stated, the International System of Units (Système International d'Unités) will be used.

3.1 Pulse Transformer Schematics

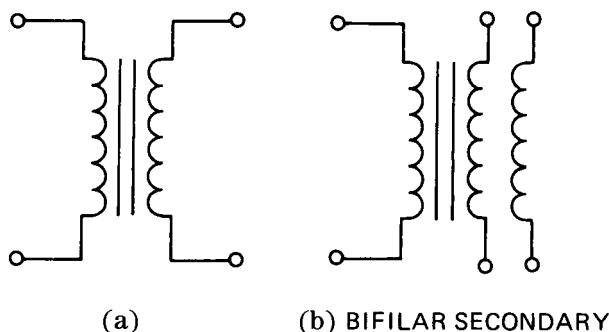

Figure 2—Pulse-Transformer Schematics

3.2 Input Pulse—Source Voltage Pulse Applied Through Associated Impedance or Source Current Pulse

The following terms are defined in Section 2.

Symbol	Term Denoted
I_M, V_M	pulse amplitude (A general amplitude quantity is designated by A , which may be current I or voltage V)
t_r	rise time (first transition duration) (10%–90% I_M or V_M unless otherwise specified)
t_f	fall time (last transition duration) (90%–10% I_T or V_T)
I_T, V_T	trailing edge (last transition) amplitude
t_p	pulse duration (90%–90% I_M or V_M)
I_Q, V_Q	quiescent value (interpulse) (base magnitude)
I_D, V_D	tilt (droop)
I_{os}, V_{os}	overshoot (first transition overshoot)
I_{RO}, V_{RO}	rolloff (rounding after first transition)
I_{RI}, V_{RI}	ringing (first transition ringing)
I_L, V_L	leading edge (first transition) linearity (10%–90% I_M or V_M)
I_{RS}, V_{RS}	return swing (last transition ringing)
I_{BS}, V_{BS}	backswing (last transition overshoot)

3.3 Output Pulse—Transformed Voltage Pulse or Load Current Pulse

The symbols of 3.2 are also used to describe the output pulse.

3.4 Source and Load Impedance

Symbol	Term Denoted
R_G	input pulse source resistance, series
L_G	input pulse source inductance, series
C_G	input pulse source capacitance, parallel
R_L	load resistance, series
L_L	load inductance, series
C_L	load capacitance, parallel

3.5 Transformer Parameters

These terms are described in Section 5.

Symbol	Term Denoted
a	transformer ratio. Where the coefficient of coupling is high, $a \cong N_2/N_1$
A_c	core cross-sectional area
B	magnetic flux density
C_{oc}	capacitive component of open-circuit admittance, shunt representation
C_{11}, C_{22}	equivalent self capacitance, winding indicated by subscripts
C_{12}	equivalent mutual capacitance between windings 1 and 2
C_D	distributed capacitance
G_{oc}	conductance component of open-circuit admittance, shunt representation
I_c	core-loss current
I_e	exciting current
I_L	load current
I_m	magnetizing current
k_f	fall time damping constant
k_r	rise time damping constant

Symbol	Term Denoted
L_{11}, L_{22}	self inductance of winding indicated by subscript
L_{11}, L_{21}	leakage inductance of winding designated by first subscript
L_m	magnetizing inductance
L_{oc}	inductive component of open-circuit impedance, shunt representation
L_{sc}	inductive component of short-circuit impedance, series representation
N_1	primary turns
N_2	secondary turns
R_{11}, R_{21}	resistance associated with leakage inductance, referred to winding indicated by first subscript
R_c	equivalent core-loss resistance, under pulse conditions shunt representation
R_{dc}	direct-current resistance of winding
R_{oc}	resistive component of open-circuit impedance, shunt representation
R_{sc}	resistive component of short-circuit impedance, series representation

4. Performance Tests

NOTE — In 4.1 through 4.3 the tests described are to determine the integrity of the transformer insulation. In 4.4 through 4.10 the tests are to control the pulse response. The tests in 4.11 and 4.12 are for additional control of pulse response in special cases. The test of 4.13 is to obtain design information for applications involving nonlinear core operation, or as an alternate or supplement to the pulse-response control tests when more direct control of pulse response is desired.

4.1 Electric Strength

This test applies to insulation between windings, between windings and core, and between windings and case.

NOTE — Transformer windings with graded insulation or windings internally or externally grounded or operated at direct voltages to ground with one terminal effectively at ground shall be tested by the induced voltage method (see 4.2).

The transformer shall withstand a sinusoidal test voltage applied for a period of one minute between each winding and all other windings and (when applicable) the core or case. The test frequency shall be 60 Hz or an alternative frequency agreed upon between the manufacturer and user (see 4.1.5).

The terminals of the winding under test shall be strapped together, and the terminals of all other windings shall be grounded and (when applicable) connected to the core or case.

4.1.1

Transformer windings operating at a peak working voltage below 25 V shall have a root-mean-square test voltage applied equal to twice the peak working voltage plus 15 V.

4.1.2

Transformer windings operating at a peak working voltage of 25 V to 100 V inclusive shall have a root-mean-square test voltage applied equal to twice the peak working voltage plus 100 V.

4.1.3

Transformer windings operating at a peak working voltage of 100 V to 700 V shall have a root-mean-square test voltage applied equal to twice the peak working voltage plus 500 V.

4.1.4

Transformer windings operating at a peak working voltage above 700 V shall have a root-mean-square test voltage applied equal to 1.4 times the peak working voltage plus 1000 V.

4.1.5

As an alternate test to 4.1.1, 4.1.2, or 4.1.3, a higher test voltage may be applied for a shorter period of time (but not less than 5 s) as negotiated between manufacturer and user. The alternate test shall stress the insulation an equivalent amount, also the frequency used may be 50 Hz to 1000 Hz.

4.1.6

Root-mean-square test voltages above 1000 V shall be applied gradually at a rate not exceeding 500 V/s, and reduced similarly.

4.2 Induced Voltage Electric Strength

This test primarily applies to insulation between layers of windings and between adjacent turns of windings, under simulated functional conditions.

The transformer shall withstand across the primary, an induced voltage pulse train for a period of at least 1 min, each pulse having an amplitude equal to 1.5 times normal operating voltage or 2.5 times normal operating voltage where circuit conditions can result in occasional two times normal voltage in operation. The pulse shall have a duration consistent with the voltage-time product of the transformer to prevent core saturation. The repetition rate of the pulse train shall be reduced to be consistent with normal average power transmitted by the transformer. If a rate less than this is to be used, the period of the test shall be increased, accordingly.

Polarity of the pulses shall be unipolar or bipolar and reset current provided according to the specific operating conditions.

The secondary shall be terminated into its nominal resistance load unless otherwise specified. Terminals normally grounded shall be grounded during this test. Any windings normally biased shall be biased for this test.

4.3 Direct-Current Insulation Resistance

The direct-current insulation resistance shall be measured between each winding and all other windings and, where applicable, the core or case. The measured value shall be greater than a specified minimum value in megohms.

4.3.1

The measurement shall be made with a direct-current test voltage of 50 V to 500 V applied but not to exceed the peak electric-strength test voltage. The test voltage shall be applied for at least 10 s before the insulation-resistance measurement is made.

4.3.2

The terminals of the winding under test shall be strapped together, and the terminals of all other windings shall be grounded and (when applicable) connected to the core or case.

4.3.3

The insulation-resistance measurement shall be made at normal room temperature and a relative humidity not greater than 80%.

4.4 Ratio of Transformation (Turns Ratio)

The ratio of transformation measurement is an electrical test that approximates the physical turns ratio of the windings.

The preferred test method is described in 6.1 and alternate test methods are shown in Appendix A.

4.5 Polarity

The polarity measurement is an electrical test that indicates the relative sense of induced voltages appearing on the windings. A dot notation is generally used to designate winding polarity (see Section 5.). A marking designated by a dot is placed at one of the two terminations of each winding, so that the instantaneous polarity of the induced voltage as measured from the dotted to the undotted terminations is the same for all windings.

Winding polarity shall be determined by comparing the voltages or impedances of transformer windings when connected series aiding and series opposing.

The polarity may be determined during the test for the ratio of transformation (see 4.2).

4.6 Direct-Current Resistance of Windings Referred to 25 °C

A bridge test method is preferred. The required measurement accuracy shall be considered in selecting the test method.

4.7 Short-Circuit Impedance (Leakage Inductance)

NOTE — In the ideal situation this measurement approaches the leakage inductance (see 5.3.1).

4.7.1

The short-circuit impedance shall be specified in terms of effective series inductance L_{sc} and series resistance R_{sc} , referred to the winding designated. The measurement is normally made on a specified winding with all other windings short circuited. If the short-circuit impedance between any two of three or more windings is especially important, one of the two windings is short circuited with all other windings open circuited.

4.7.2

The preferred test method is described in 6.2 and an alternate method in Appendix A.

4.8 Open-Circuit Parameters (Magnetizing Pulse Inductance and Exciting Current)

NOTE — In the ideal situation this measurement provides the magnetizing pulse inductance (see 5.3.2).

4.8.1

Magnetic preconditioning (if applicable) shall be performed on the transformer core prior to making this test (that is, placing the core flux in a demagnetized state). The effects of disaccommodation shall be considered in determining the time after preconditioning that the measurement is made, especially in the case of ferrite cores.

4.8.2

The open-circuit parameters shall be specified in terms of the effective shunt inductance L_{oc} , and shunt resistance R_{oc} . The measurement shall be made on a specified winding with all other windings open circuited.

4.8.3

The measurement is normally made by applying unipolar or bipolar voltage pulses (as appropriate for transformer application) from a low-impedance source, and observing the resultant exciting current pulses. Inductance and resistance are calculated as shown in 6.4. The applied voltage pulses shall have the ideal rectangular shape, or approximate the transformer's functional pulse shape. The source impedance or input circuit configuration, and input pulse parameters, such as amplitude, rise time (first transition duration), fall time (last transition duration), duration, tilt (droop), overshoot (after first transition), rolloff (rounding after first transition), ringing (after first transition), leading edge (first transition), linearity, and pulse repetition frequency, shall be specified for this test because the pulse inductance is a function of these items. Test temperature shall also be specified.

4.8.4

The recommended test method for low-power pulse transformers is described in 6.4 and alternate pulse and sinusoidal test methods are shown in Appendix A.

The recommended method for high-power pulse transformers (see 6.4) simulates the transformer's functional circuit. Accordingly, the pulse-forming network and its charging rate shall be consistent with the application. The pulse inductance is a function of: amplitude, rise time (first transition duration), fall time (last transition duration), duration, tilt (droop), overshoot (after first transition), rolloff (rounding after first transition), leading edge (first transition), linearity, and pulse-repetition frequency. Test temperature shall also be specified.

4.8.5

In some instances, the pulse-exciting current response to a specified voltage pulse is used directly in place of the derived R and L values. The test normally involves measuring the peak value of the resultant exciting-current pulse when a rectangular voltage pulse of specified voltage and duration is applied from a low-impedance source (see 6.4).

4.9 Open-Circuit Admittance (Distributed Capacitance)

NOTE — In the ideal situation this measurement provides the distributed capacitance (see 5.3.3).

4.9.1

The open-circuit admittance shall be specified in terms of effective shunt capacitance C_{oc} , and conductance G_{oc} . The open-circuit capacitance represents the electrical effect of all stray capacitance within the transformer referred to the terminations of the winding under test. The measurement shall be made on a specified winding with all other windings open circuited. Winding terminals, electrostatic shields, core, or case normally grounded in the transformer's intended application shall be grounded for this test. Normally, the high-impedance winding is measured.

4.9.2

The preferred test methods are described in 6.3. Alternate test methods are shown in Appendix A.

4.10 Voltage-Time Product Rating

NOTE — The voltage time product rating of a transformer winding is intended as an aid in pulse transformer application.

4.10.1

The voltage-time product is often determined by observing the pulse exciting current (see 4.8 and 6.4). In that case, the voltage-time product of a winding is specified as the maximum voltage-time integral of a rectangular voltage pulse that can be applied to the winding before core saturation effects cause the resultant exciting-current pulse waveform to deviate from a linear ramp by a given percentage (see 6.5).

4.10.2

Generally, the applied pulse voltage amplitude shall be that recommended in 6.4. It shall not exceed the test voltage used in the induced voltage electric-strength test, 4.2, and the pulse-repetition frequency shall be kept sufficiently low to prevent transformer heating that could affect the magnetic characteristics or damage the transformer. Forcing the core flux at rates greater than normal for the core material will not yield the correct voltage-time product. The recommended pulse duration for the determination of this rating is that for which the transformer was designed. The voltage-time product does not remain constant when the pulse duration is very short. The applied voltage pulses shall be unipolar or bipolar as appropriate for the transformer application. When the transformer application involves a direct current in any of the windings, the measurement shall be made with rated direct-current ampere turns applied through a suitable impedance to prevent pulse-loading effects. Input-pulse source impedance and pulse parameters, as listed in 4.8, shall be specified for this test.

4.10.3

The preferred test method for voltage-time product is described in 6.5.

4.11 Direct Capacitance Between Windings

The direct capacitance measurement is made in special cases, for example, to determine whether an electrostatic shield is properly installed and connected.

The two windings under consideration shall have their terminals strapped together during this test; and all other conductive elements such as core, case, electrostatic shields, and other windings shall be grounded, ungrounded (floating), or connected to the guard terminal of the capacitance bridge as specified.

4.12 Balance

The balance measurement is made in special cases where the transformer winding balance is important, for example, memory read-out transformers. Preferred test methods are shown in 6.6.

4.13 Functional Test

NOTE — The functional test is performed to obtain design information when nonlinear core operation is involved (for example, blocking-oscillator transformer), or as an alternate, or to supplement the tests given in 4.4 through 4.10 when a more direct control of the pulse response is desired. In many cases, however, functional tests require the use of specialized equipment (for example, high-power modulators, klystrons, radio-frequency (rf) loads, etc). Therefore, if mutually agreeable, these tests may be designated as acceptance tests, to be performed by the user on his equipment.

4.13.1 Test Conditions

4.13.1.1

The following conditions shall be specified for the functional tests:

- 1) Input Pulses
 - a) Pulse repetition frequency (or pulse program time intervals)
 - b) Input pulses shall each have the following information specified:
 - i) Type of pulse: Current pulse, or source-voltage pulse applied through associated impedance
 - ii) Pulse parameters: Amplitude, rise time (first transition duration), fall time (last transition duration), duration, tilt (droop), overshoot (after first transition), rolloff (rounding after first transition), ringing (after first transition), leading edge (first transition) linearity, and quiescent level (base magnitude)
 - iii) Pulse source impedance: resistance, capacitance, inductance; or input circuit configuration
 - iv) Designation of winding to which pulse is applied
- 2) Load
 - a) Load resistance, inductance, and capacitance; or load-circuit configuration
 - b) Designation of winding (s) to which load is connected
- 3) Response
 - a) Designation of type of response: voltage or current
 - b) Designation of winding(s) at which response is to be measured

4.13.1.2

The functional test response shall be measured using a wideband direct-coupled oscilloscope with a high-impedance probe and an oscilloscope pulse calibrator.

4.13.1.3

As an alternate to 4.13.1.1(1) in cases where the input pulse cannot be accurately defined (for example, blocking oscillator circuits), the complete circuit configuration, including all circuit elements and applied voltages and currents shall be accurately defined.

4.13.2 Pulse Response

As applicable, one or more of the following pulse-response characteristics shall be measured.

NOTE — These terms are defined in Sections 2. and 5.

- 1) Amplitude
- 2) Rise time (first transition duration)
- 3) Fall time (last transition duration)
- 4) Duration
- 5) Tilt (droop)
- 6) Overshoot (after first transition)
- 7) Roll off (rounding after first transition)
- 8) Ringing (after first transition)
- 9) Leading edge (first transition) linearity
- 10) Recovery time
- 11) Return swing (last transition ringing)
- 12) Backswing (last transition overshoot)
- 13) Trailing edge roll off (rounding after last transition)
- 14) Trailing edge (last transition) linearity
- 15) Tilt (droop) linearity
- 16) Damping on leading edge (first transition) (under, over, critically damped)
- 17) Damping after trailing edge (last transition) (under, over, critically damped)

4.14 Corona (Partial Discharge) Tests

The transformer shall be free from visible discharges at 130% of rated operating voltage (see 6.8).

4.15 Temperature Rise Test

When required, this test shall be made on a representative model of each new design. This test shall be made with the transformer terminated in its actual or simulated load and at the specified duty cycle. Ambient conditions shall be in accordance with the specification. This test may be performed by the user (see 6.7).

5. Equivalent Circuits

5.1 Complete Equivalent Circuit for a Pulse Transformer

5.1.1

The *complete* equivalent circuit for a pulse transformer is shown in Fig 3(a). An alternate form, showing the transformer parameters referred to the primary winding, is shown in Fig 3(b).

NOTE — Sometimes a small inductance is shown in series with R_c , and a small inductance in series with each capacitor.

5.1.2

A comparison of equivalent circuits for pulse and wideband transformers is discussed in this section.

5.1.2.1

The equivalent circuits of Fig 3 are equally applicable to pulse and wideband transformers. See ANSI/IEEE Std 100-1984 [1], IEEE Std 194-1977 [10], ANSI/IEEE Std 260-1978 (R 1985) [3], and [14]. Since both types of transformers are capable of transforming voltage waveforms, which in the frequency domain contain a wide range of frequencies, a given transformer can be used in either a pulse or wideband application. The principal difference is that for pulse transformers the design and performance considerations are in the time domain rather than in the frequency domain.

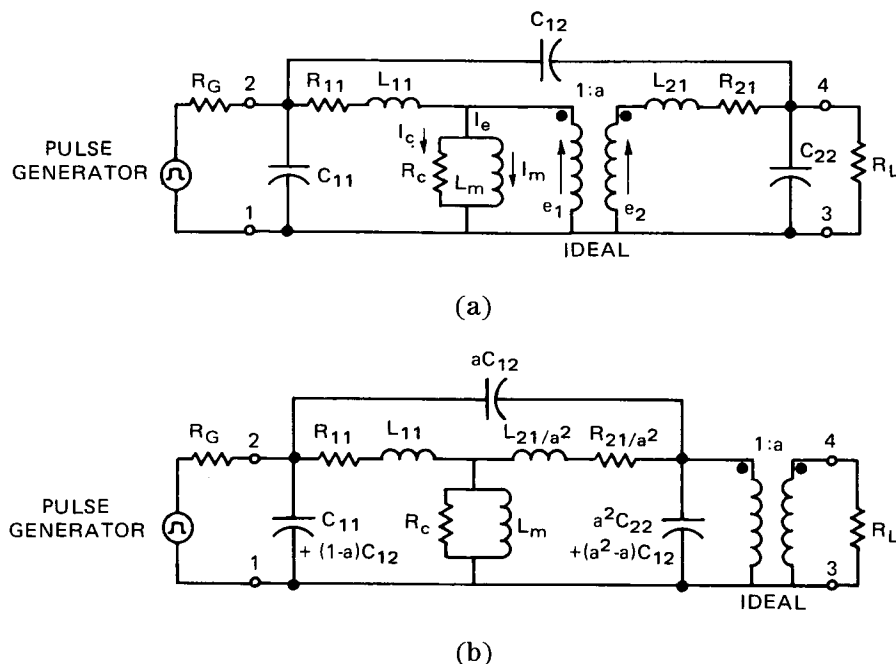

Figure 3—(a) Complete Equivalent Circuit for a Pulse Transformer (b) Alternate Form of Complete Equivalent Circuit for a Pulse Transformer

5.1.2.2

For a given transformer, the values of many equivalent circuit elements are the same for pulse and wideband application. These are the elements that are essentially independent of the core excitation. They include transformer ratio a , primary and secondary winding resistances R_{11} , and R_{21} , primary and secondary leakage inductances L_{11} and L_{21} , and transformer capacitances (distributed capacitances C_{11} and C_{22} and interwinding capacitance C_{12}).

Since the transformer capacitances are dependent upon the voltage distribution on the windings, they are somewhat dependent upon the type of excitation.

However, the equivalent circuit elements closely associated with the nonlinear magnetic core are highly dependent upon the type of excitation. These are the magnetizing inductance L_m and core-loss resistance R_c .

The magnetizing inductance depends upon the manner in which the core flux traverses a B—H loop. For a wideband transformer, the flux excitation is essentially sinusoidal and the B—H loop traversed is symmetrical about the origin. For a pulse transformer, the core receives pulse excitation and yields a symmetrical B—H loop when bipolar pulses are transformed, and an asymmetrical B—H loop when unipolar pulses are transformed. See Fig 4. When the core receives current reset, still another asymmetrical loop is traversed.

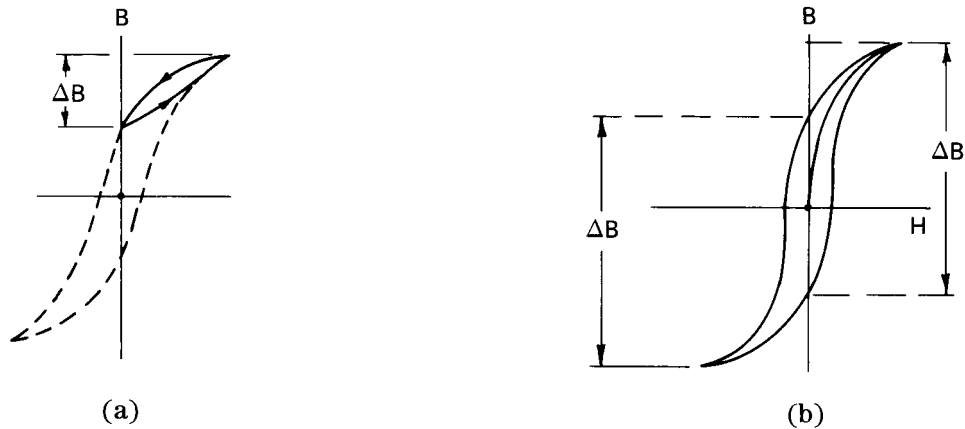

Figure 4—(a) Asymmetrical B—H Loop (b) Symmetrical B—H Loop

5.1.2.3

The pulse transformer equivalent circuit elements that are not dependent upon the core excitation can be measured under either pulse or sinusoidal excitation. However, the magnetizing inductance and core-loss resistance must be measured under pulse conditions as close to functional operation as possible for the measurements to be meaningful.

5.2 Partial Equivalent Circuits for a Pulse Transformer

The pulse transformer equivalent circuit may be reduced to three simplified circuits, each applicable to a portion of the pulse in the time domain.

- 1) Pulse leading edge (pulse first transition)
- 2) Pulse top
- 3) Pulse trailing edge (pulse last transition)

5.2.1

The pulse leading edge (pulse first transition) *partial* equivalent circuit for a pulse transformer is shown in Fig 5 (a).

5.2.1.1

The circuit is similar to the high-frequency approximation equivalent circuit for the wideband transformer (see IEEE Std 194-1977 [10], ANSI/IEEE Std 260-1978 (R 1985), and [14]). The circuit yields the response to a step function applied to a pulse transformer. The rapidly changing portion of the pulse corresponds to high frequencies in the frequency domain, permitting removal of the high-reactance shunt element due to magnetizing inductance shown in the *complete* equivalent circuit. The *L* configuration is appropriate for a step-up transformer where the secondary distributed capacitance predominates.

5.2.1.2

The equations for the response of the circuit to an applied step function under overdamped, oscillatory, and critically damped conditions are given in Fig 5 (b).

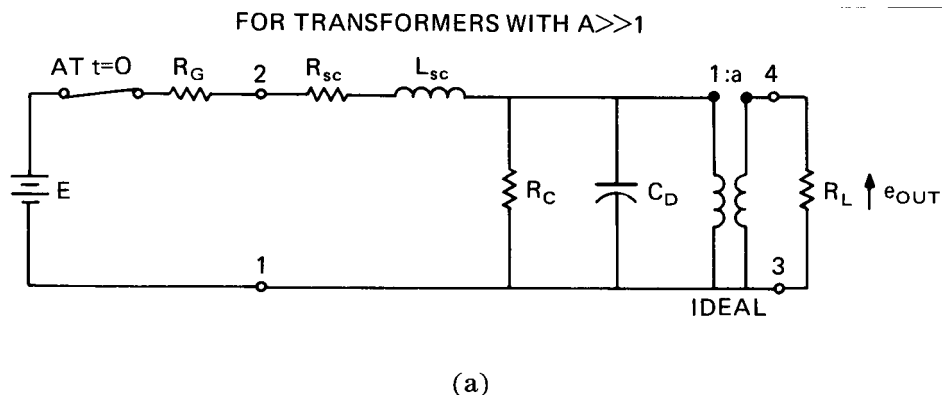

For transformers with $a \gg 1$.

$k_r > 1$ (overdamped)

$$\frac{e_o(t)}{aEa_r} = 1 - e^{-2\pi k_r x_r} \left[\frac{k_r}{\sqrt{k_r^2 - 1}} \sinh \left(2\pi x_r \sqrt{k_r^2 - 1} \right) + \cosh \left(2\pi x_r \sqrt{k_r^2 - 1} \right) \right]$$

$k_r < 1$ (oscillatory)

$$\frac{e_o(t)}{aEa_r} = 1 - e^{-2\pi k_r x_r} \left[\frac{k_r}{\sqrt{1 - k_r^2}} \sin \left(2\pi x_r \sqrt{1 - k_r^2} \right) + \cos \left(2\pi x_r \sqrt{1 - k_r^2} \right) \right]$$

$k_r = 1$ (critically damped)

$$\frac{e_o(t)}{aEa_r} = 1 - e^{-2\pi x_r} (2\pi x_r + 1)$$

$$\text{Rise time resistance constant } a_r = \frac{1}{R_{sc} \left(\frac{a^2}{R_L} + \frac{1}{R_c} \right) + \frac{a^2 R_G}{R_L} + \frac{R_G}{R_c} + 1}$$

$$\text{Rise time damping constant } k_r = \frac{t'}{2\pi} \left(\frac{R_G + R_{sc}}{2L_{sc}} + \frac{\frac{a^2}{R_L} + \frac{1}{R_c}}{2C_D} \right)$$

$$\text{Fractional rise time } x_r = \frac{t}{t'}$$

$$\text{Rise time normalizer } t' = 2\pi \sqrt{L_{sc} C_D} a_r$$

(b)

Figure 5—(a) Pulse Leading Edge (Pulse First Transition) Partial Equivalent Circuit for Pulse Transformer with $a \gg 1$ (b) Response of Circuit (a) to Applied Step Function

5.2.1.3

Curves of transformer leading edge response are shown in ANSI/IEEE Std 100-1984 [1], ANSI/IEEE Std 260-1978 (R 1985), and [14].

5.2.1.4

The rise time t_r may also be related to the frequency of the 3 dB point f_h , at the high-frequency end of the frequency-loss characteristic of the wideband transformer as follows:

$$f_h \cong \frac{0.382}{t_r}$$

where

- t_r = rise time (first transition duration) (10%–90% unless otherwise specified) μ s of A_m
- f_h = upper 3 dB point, MHz

5.2.2

The pulse-top *partial* equivalent circuit for a pulse transformer is shown in Fig 6(a).

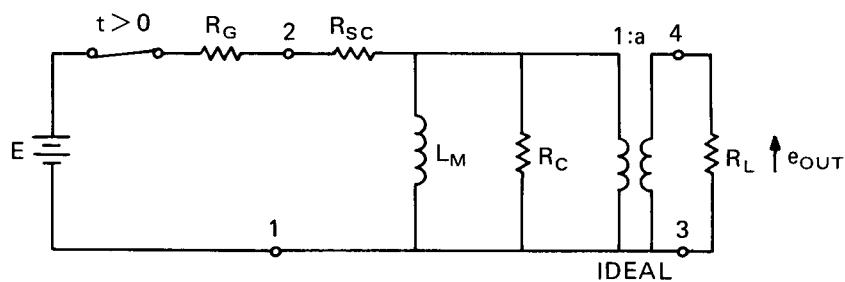

(a)

$$\frac{e_o(t)}{a E a_r} = e^{[-(R_G + R_{sc}) a_r / L_M] t}$$

where

$$a_r = \frac{1}{R_{sc} \left(\frac{a^2}{R_L} + \frac{1}{R_c} \right) + \frac{a^2 R_G}{R_L} + \frac{R_G}{R_c} + 1}$$

(b)

Figure 6—(a) Pulse Top Partial Equivalent Circuit for Pulse Transformer (b) Response to Circuit (a) to Constant Voltage (E)

5.2.2.1

The circuit is similar to the low-frequency approximation equivalent circuit for the wideband transformer (see [2], [4], and [6]). The circuit yields the response to the unchanging flat-top portion of a pulse applied to a pulse transformer. This slowly changing portion of the pulse corresponds to low frequencies in the frequency domain, permitting removal of the low-reactance series element due to leakage inductance and the high-reactance shunt elements due to distributed capacitances.

5.2.2.2

Figure 6 (b) shows the equations for the response of the circuit to a constant voltage E applied at a time corresponding to the beginning of the pulse top. The equation gives the tilt (droop) of the *transformed* pulse top. For shortpulse duration

where

$$\begin{aligned}
 R t_p / L_m &< 0.2 \\
 R t_p / L_m &= \text{tilt (droop)} \\
 R &= \text{parallel combination of} \\
 &\quad R_G + R_{sc} \\
 &\quad R_c \\
 &\quad R_L / a^2
 \end{aligned}$$

5.2.2.3

The tilt (droop) A_D may also be related to the frequency of the 3 dB point f_1 , at the low-frequency end of the frequency-loss characteristic of the wideband transformer, as follows:

$$A_D \cong 2\pi f_1 t_p$$

where

$$\begin{aligned}
 A_D &= \text{tilt (droop); s, Hz} \\
 f_1 &= \text{low frequency 3 dB point, Hz} \\
 t_p &= \text{pulse duration, s (interval between 90\% of } A_M \text{ and 90\% of } A_T \text{) See Fig 1}
 \end{aligned}$$

5.2.3

The pulse trailing edge (pulse last transition) and backswing (last transition overshoot) *partial* equivalent circuit for a pulse transformer are shown in Fig 7 (a).

5.2.3.1

The pulse trailing edge (pulse last transition) and backswing (last transition overshoot) circuit has no corresponding circuit for a wideband transformer. The circuit yields the response to the trailing edge (last transition) of the applied voltage pulse.

5.2.3.2

Figure 7(b) shows equations for the response of the circuit to a change from application of a constant voltage E applied for a relatively long period of time through resistance R_c with load resistance R_L , to application of zero voltage through R'_G with load resistance R'_L applied. The change occurs at the beginning of the pulse trailing edge (pulse last transition) at the conclusion of the pulse duration. The response is shown for overdamped, oscillatory, and critically damped conditions. At the transition time ($t = 0$), the current flowing in the magnetizing inductance is dissipated in the parallel RLC circuit, giving the trailing edge (last transition) response.

Equations are also given to determine the time corresponding to the maximum backswing voltage (last transition overshoot). The value of backswing (last transition overshoot) voltage can then be determined by substituting this time into the response equation.

NOTE — $t = 0$ occurs at the conclusion of the pulse duration, that is, the beginning of the pulse trailing edge (pulse last transition)

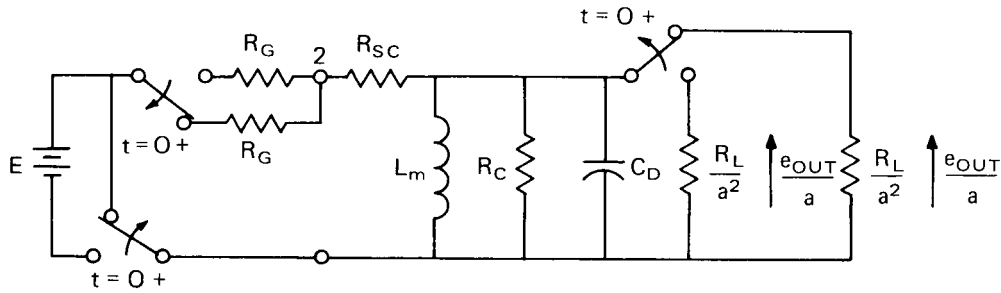

$k_f > 1$ (overdamped)

$$\frac{e_o(t)}{aV_0} = \frac{1}{2\gamma_1} \left[\left(C_1 + \frac{\Delta P}{R_G C_D} \right) e^{-C_1 t} - \left(C_2 + \frac{\Delta P}{R_G C_D} \right) e^{-C_2 t} \right]$$

$k_f < 1$ (oscillatory)

$$\frac{e_o(t)}{aV_0} = \left[\cos \gamma_2 t - \frac{1}{\gamma_2} \left(\alpha_f + \frac{\Delta P}{R_G C_D} \right) \sin \gamma_2 t \right]$$

$k_f < 1$ (critically damped)

$$\frac{e_o(t)}{aV_0} = \left[1 - \left(\alpha_f + \frac{\Delta P}{R_G C_D} \right) t \right] e^{-\alpha_f t}$$

Time of maximum backswing voltage (last-transition overshoot)

$k_f > 1$

$$t_{e_{max}} = \frac{\ln C_2 [C_2 + (\Delta P/R_G C_D)] / C_1 [C_1 + (\Delta P/R_G C_D)]}{C_2 - C_1}$$

$k_f = 1$

$$t_{e_{max}} = \frac{2\alpha_f + (\Delta P/R_G C_D)}{\alpha_f (\alpha_f + \Delta P/R_G C_D)}$$

$k_f < 1$

$$t_{e_{max}} = \frac{1}{\gamma_2} \tan^{-1} - \left(\frac{\alpha_f}{\gamma_2} + \frac{\Delta P}{R_G C_D} \right)$$

V_0 = initial voltage on C_D at $t = 0$ (end of pulse duration)

$$V_0 = [I_{load} \text{ (at time } t = 0-)] \frac{R_L}{a^2}$$

$$\alpha_f = \frac{1}{2 C_D \left[\frac{1}{R_{sc}} + \frac{1}{R_c} + \frac{a^2}{R_L} - \frac{R'_G}{(R'_G + R_{sc}) R_{sc}} \right]}$$

$$k_f = \alpha_f \sqrt{L_m C_D}$$

$$\gamma_1 = \frac{\alpha_f}{k_f} \sqrt{k_f^2 - 1}$$

$$\gamma_2 = \frac{\alpha_f}{k_f} \sqrt{1 - k_f^2}$$

$$C_1 = \alpha_f + \gamma_1$$

$$C_2 = \alpha_f - \gamma_1$$

$$\Delta = \frac{I_m}{I_{load}} \text{ (at time } t = 0-)$$

$$P = \frac{R_G}{R_L} a^2$$

Figure 7—(a) Pulse Trailing Edge (Pulse Last Transition) Partial Equivalent Circuit for Pulse Transformer (b) Response of Circuit (a) to Pulse Trailing Edge

5.2.3.3

Equations and curves of transformer trailing edge (last transition) response are shown in ANSI/IEEE Std 100-1984 [1], ANSI/IEEE Std 260-1978 (R 1985) [3], and [14].

5.3 Pulse Transformer Tests to Determine Equivalent Circuit Elements

5.3.1 Short-Circuit Parameters (Leakage Inductance)

In the ideal situation, the short-circuit impedance measurement provides the leakage inductance. Referring to Fig 3, with the pulse source and R_G and R_L removed, the impedance is measured across terminals 1–2 with terminals 3–4 short circuited.

The measurement is made at a low enough frequency where the reactance of the capacitances becomes high enough to neglect. The impedance thus becomes the primary leakage elements R_{11} and L_{11} in series with the combination R_{21}/a^2 and L_{21}/a^2 in parallel with L_m and R_c . However, for transformers with high coupling between windings, the magnetizing inductance L_m is much greater than the transformed secondary leakage inductance L_{21}/a^2 , and the shunting effect of L_m and R_c can usually be ignored. The short-circuit impedance then becomes the series combination of the elements R_{11} , R_{21}/a^2 , L_{11} , L_{21}/a^2 , thus determining the leakage elements.

The test procedure and recommended test method are described in 4.7 and 6.2, respectively. A sinusoidal measurement of the leakage elements is appropriate as discussed in 5.1.

5.3.2 Open-Circuit Parameters (Magnetizing Pulse Inductance)

In the ideal situation, the open-circuit impedance measurement provides the magnetizing pulse inductance. Referring to Fig 3, with the pulse source and R_G and R_L removed, the parameters are measured across terminals 1–2 with terminals 3–4 open circuited. (The parameters should be determined on a pulse basis as discussed in 5.1. Methods of performing the measurement are described in 4.8 and 6.4 and in Appendix A.)

If the measurement is performed under conditions where the effect of the capacitive reactances can be neglected, the input impedance becomes the primary leakage elements R_{11} and L_{11} in series with the parallel combination of R_c and L_m . Again, for tightly coupled windings, $L_{11} \ll L_m$, and the input parameters are approximately the parallel combination of the elements R_c and L_m .

A method for determining each of these elements under pulse conditions, involving dividing the exciting-pulse current I_e into its two components, the core-loss current I_c and the magnetizing-pulse current I_m is shown in 6.4.

5.3.3 Open-Circuit Admittance

A sinusoidal measurement of the winding capacitive elements is appropriate, as discussed in 5.1.

In the ideal situation, the open-circuit admittance measurement provides the distributed capacitance. The objective of the test is to determine the winding capacitive elements of Fig 3. Referring to Fig 3, with the pulse source and R_G and R_L removed, the admittance is measured across terminals 1–2 with terminals 3–4 open circuited. The measurement is made at a high frequency, where the capacitive reactance becomes significant.

For the recommended bridge test method of 6.3, the open-circuit admittance is measured at a frequency where the admittance is capacitive. Determination of equivalent circuit capacitive elements by this method will be described for a step-up pulse transformer. For simplicity, the interwinding capacitance C_{12} will be assumed to be negligible. For a step-up transformer ($a > 1$), the transformed secondary capacitance $a^2 C_{22}$ predominates over the primary winding capacitance, so C_{11} will be neglected. Similarly, the transformed leakage elements L_{21}/a^2 and R_{21}/a^2 become small enough to neglect. The circuit is thus simplified to an L configuration consisting of R_{11} and L_{11} elements in series with the parallel combination of R_c , L_m , and $a^2 C_{22}$.

At low frequencies, the input admittance is inductive and roughly equal to L_m . The first resonance is of L_m with $a^2 C_{22}$, and at frequencies somewhat above this resonance, the input admittance is capacitive. At higher frequencies, the effective input capacitance levels off at $a^2 C_{22}$, but at still higher frequencies, the effective capacitance increases as the resonance of L_{11} with $a^2 C_{22}$ is approached (an example curve showing this resonance is shown in IEEE Std 194-1977 [10]).

When the first and second transformer resonant frequencies are well separated this method gives an accurate measurement of the secondary winding capacitance.

Other test methods measure the open-circuit admittance at frequencies below the first resonance, where the admittance is inductive. They assume the transformer input appears as L_m in parallel with $a^2 C_{22}$.

5.4 Pulse Response Parameters Under Load

Pulse transformer rise time can be measured in the end-use system. The usual problem, however, is one of predicting the rise time, lacking the physical system that will ultimately incorporate the pulse transformer. Such a prediction can be made quite accurately for a linear load, knowing the load capacitance, load resistance, source resistance, transformer leakage inductance, and distributed capacitance. Any stray capacitances such as socketry or capacitance to tank walls must be included. Rise time and overshoot can then be calculated (see ANSI/IEEE Std 100-1984 [1]). Nonlinear loads require special treatment. For example, a magnetron exhibits an open circuit until it fires. A klystron exhibits a resistance proportional to the $3/2$ power of the voltage. Such nonlinear effects modify the rise time and overshoot as calculated for a linear load. For specification purposes, the linear load performance is a good common ground for defining rise time and overshoot, except, perhaps, for magnetron devices that are very nonlinear. Some magnetrons will double-mode if the voltage rate of rise and current overshoot are not held below specified limits.

6. Preferred Test Methods

In performing all tests, safety precautions should be strictly observed since voltages involved are much higher than those normally encountered, and, wherever possible, safety interlocks should be employed. This is especially true where high voltage is applied to the transformer under test, such as in the load test and the induced-voltage test. Since high-frequency pulses and heavy peak currents are involved, all ground connections should be made as direct as possible and should be of heavy copper strapping or sheeting brought to a single ground point to avoid loops. Noninductive loads, current-viewing transformers, and wideband voltage dividers are required.

6.1 Ratio of Transformation (Turns Ratio) Test Method (See 4.4)

NOTE — In the case of tightly coupled windings, near unity turns ratio, and winding resistances that divide as the turns ratio, the ratio of transformation measurement closely approximates the physical turns ratio.

The ratio of transformation of two windings shall be determined by connecting the windings series aiding in the production of magnetic flux, applying a sinusoidal voltage to the series configuration, and measuring the voltage ratio using a calibrated potentiometer and null meter.

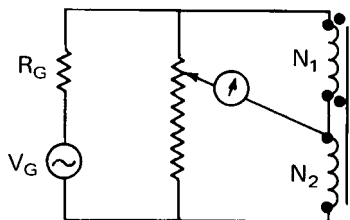

Figure 8—Series Method Test Circuit for Measuring Ratio of Transformation

The test frequency should be high enough so that the effect of any winding resistance imbalance will be negligible. The series method minimizes the effect of winding resistance. The common current driving both windings is less than the current with single winding excitation, giving lower resistive voltage drops; and with drops in both windings there is an offsetting effect in the measurement of voltage ratio.

The variable element used to obtain a null can be either a resistor or an inductor.

Alternate test methods are shown in Appendix A.

6.2 Short-Circuit Impedance (Leakage Inductance) Test Method (See 4.7)

NOTE — In the ideal situation this measurement provides the leakage inductance (see Section 5.).

The short-circuit impedance test should be performed using a suitable inductance bridge operating in the frequency band of the transformer being measured.

The test shall be made at a frequency close to the minimum in the curve of effective series inductance L_{sc} , versus frequency. An example of this curve is shown in IEEE Std 194-1977 [10].

A sinusoidal measurement is appropriate for the short-circuit impedance of a pulse transformer. Short-circuit impedance is almost independent of the core material, and therefore pulse excitation of the core is not necessary (see Section 5.).

Windings that are short circuited should have the shorting conductors applied in such a manner as to ensure a low-resistance low-inductance connection.

An alternate test method is shown in Appendix A.

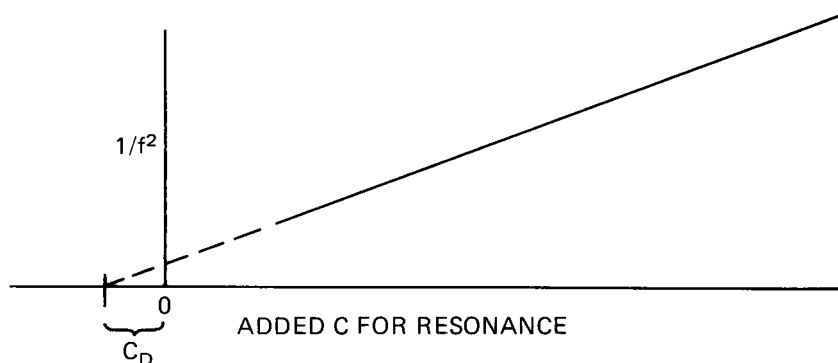

Figure 9— $1/f^2$ As a Function of Added Capacitance

6.3 Open-Circuit Admittance (Distributed Capacitance) Test Methods (See 4.9)

NOTE — In the ideal situation this measurement provides the distributed capacitance (see Section 5.).

6.3.1 Impedance Bridge Method

The open-circuit capacitance test shall be performed using a suitable capacitance bridge operating at a high frequency where the admittance is capacitive. The frequency shall be in the region between the first and second resonances of the windings. The test frequency is normally set near the point of inflection in the curve of effective capacitance C_{oc} versus frequency, that is, the point where the slope reaches a minimum between two maxima. An example of this curve is shown in IEEE Std 194-1977 [10].

6.3.2 Self-Resonance With Constant Current Excitation

The open-circuit capacitance may be obtained by observing the capacitance that must be added to tune the transformer winding to resonance at several frequencies with constant current excitation. A plot of the added capacitance as a function of $1/f^2$ can be approximated by a straight line that intercepts the axis at a negative value equal to the self-resonant capacitance, or effective distributed capacitance C_D (see Fig 9).

The slope of the line gives the approximate sinusoidal magnetizing inductance according to the equation

$$L = m/4\pi^2$$

where

$$m = \text{slope of } 1/f^2 \text{ versus added capacitance}$$

Additional test methods are shown in Appendix A.

6.3.3 Self-Resonant Method With Air-Core Inductance Shunt

NOTE — This test shall be performed with a low-loss (high Q) air-core inductor, having an inductance approximately equal to 10 times the leakage inductance L_{11} , as determined in the test method of 6.2, connected in shunt with the primary winding.

If the leakage inductance is determined for the secondary winding as L_{21} , this air-core inductance shunt is then equal to $10/a^2 \cdot L_{21}$, approximately.

The effective distributed capacitance shall be obtained by observing the capacitance that must be added to tune the transformer secondary winding to resonance at several frequencies, with the primary winding shunted by an air-core inductor having an inductance equal to approximately $10 L_{11}$ (see NOTE). Plot the added capacitance for resonance as a function of $1/f^2$. Draw a straight line that most nearly connects these points to intercept the abscissa at a negative value, which is equal to the effective capacitance C_D (see Appendix A for several other alternate procedures).

6.4 Open-Circuit Impedance (Magnetizing Pulse Inductance and Exciting Current) Test Method. Recommended Method: Rectangular Voltage Pulse Applied from Low-Impedance Source, and Pulse-Exciting Current Response Observed (See 4.8)

NOTE — In the ideal situation this measurement provides the magnetizing pulse inductance (see Section 5.).

6.4.1

An example of a recommended test circuit for unipolar excitation is shown in Fig 10. The source of the test circuit is [13]. The voltage across the test winding V_i is adjusted by V_{cc} and is equal to $V_{cc} V_{ce}$. The pulse duration is controlled by means of the pulse generator, whose amplitude is adjusted to minimize the distortion of the V_i waveform from the ideal rectangular wave. The tilt (droop) of V_i shall not exceed 2%. The test shall be performed at rated voltage. If the transformer application involves a direct current in any of the windings, the test shall be performed with rated direct-current magnetomotive force applied through a suitable impedance, to prevent pulse loading effects.

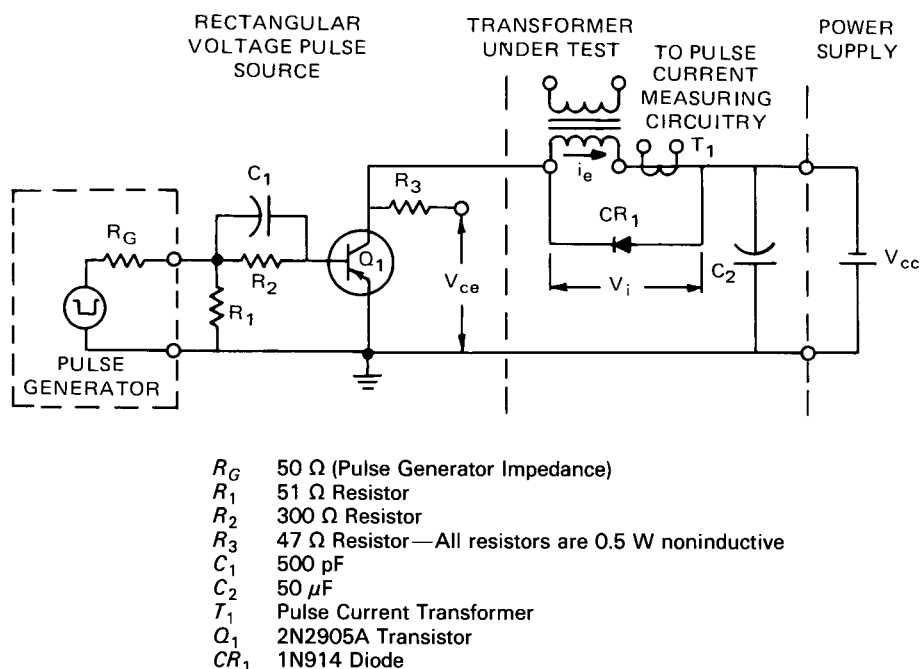

Figure 10—Example of a Test Circuit for the Recommended Method of Determining Magnetizing Pulse Inductance

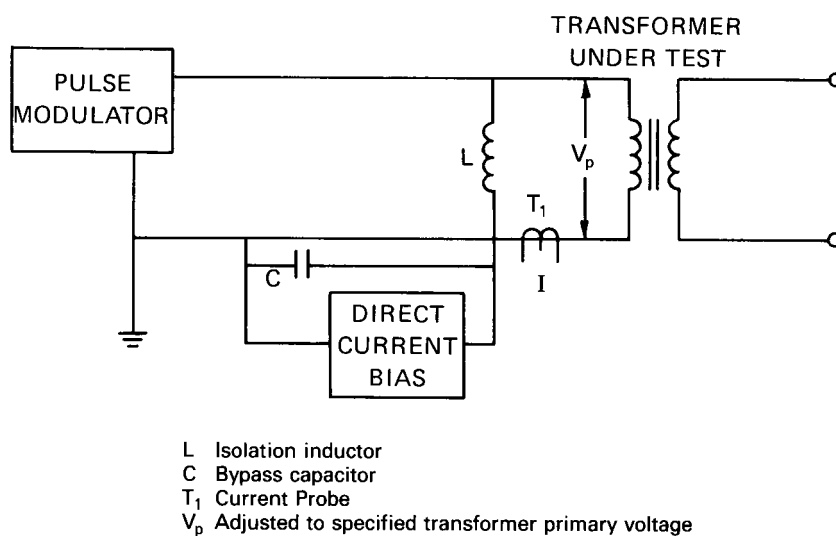

Figure 11—Recommended Test Circuit for Rectangular Pulse Excitation Using a Pulse Modulator

An example of a recommended test circuit for high-power pulse transformers using a pulse modulator is shown in Fig 11. In general, a pulse source simulating the circuit in which the transformer will be used shall be employed in the test circuit.

6.4.2

The pulse exciting current in a winding is the resultant current caused by the application of a voltage pulse. For the application of a rectangular voltage pulse it usually has the shape of a ramp in the time domain according to the formula $di/dt = e/L$. The exciting current waveform is idealized in Fig 12 and is displayed on an oscilloscope by means of the current probe.

The front edge of the current pulse represents a measure of effective shunt resistance across the winding. This is usually referred to as core-loss resistance.

I_c is a spike that sometimes is visible and is due to an initial charging of stray primary capacitance. The center portion, or the actual ramp, represents the variation of current with time due to the *magnetizing pulse inductance* of the winding. The trailing edge represents the current decay after the voltage pulse terminates. In small low-power pulse transformers, normally a sharp leading edge, a linear middle portion, and an exponential decaying trailing edge are observed.

The effective shunt resistance is determined by

$$R_c = \frac{V_i}{I_R}$$

The average exciting *impedance* at a time t_2 is:

$$Z_e = \frac{V_i}{I_2}$$

The incremental *magnetizing pulse inductance* from t_1 to t_2 is

$$L_m = \frac{V_i (t_2 - t_1)}{I_2 - I_1}$$

The maximum change in flux density B in the core is determined by

$$\Delta B = \frac{V_i (t_2 - t_1)}{N A_c}$$

Coil standards having either air cores or powdered nickel-iron cores⁴ shall be used in correlation checks of magnetizing pulse inductance measurements.

The applied voltage pulses shall be unipolar or bipolar as appropriate for transformer application.

Alternate test methods are shown in Appendix A.

⁴For example, Permalloy.

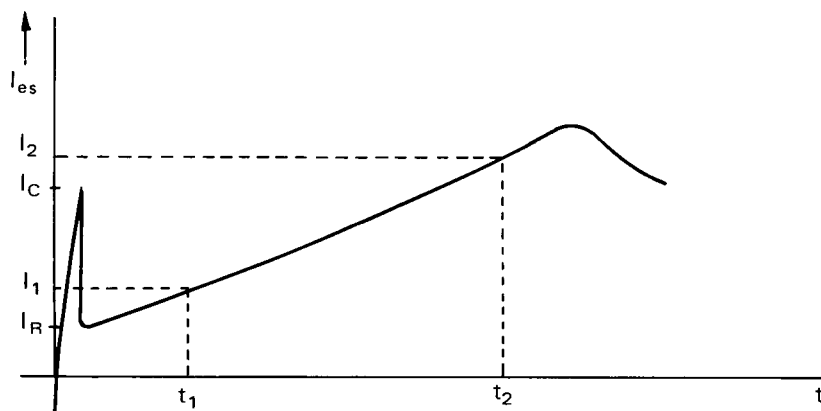

Figure 12—Exciting Current Waveform

6.5 Voltage-Time Product Test Method. Recommended Methods: Rectangular Voltage Pulse Applied from Low-Impedance Source and Pulse-Exciting Current Response Observed (See 4.10)

NOTE — This test method is almost the same as the recommended test method for open-circuit parameters (magnetizing pulse inductance and exciting current) described in 6.4.

6.5.1

The voltage-time product of a winding shall be measured as the product of the pulse voltage amplitude of a rectangular voltage pulse applied to the winding and the pulse duration measured at a time t_2 where the resultant pulse exciting current has increased to a certain value, which is a specified percentage (for example, 50%) above the linearly extrapolated value of the linear ramp waveform. The departure of the exciting current waveform from a linear ramp as shown in Fig 13 is due to a rapid decrease in magnetizing pulse inductance as the core flux reaches the saturation region.

The tilt (droop) of the applied voltage pulse shall be less than 2%.

6.5.2

Test conditions shall be as specified in 4.10 and also as specified for the open-circuit parameter test as described in 4.8 and 6.4.

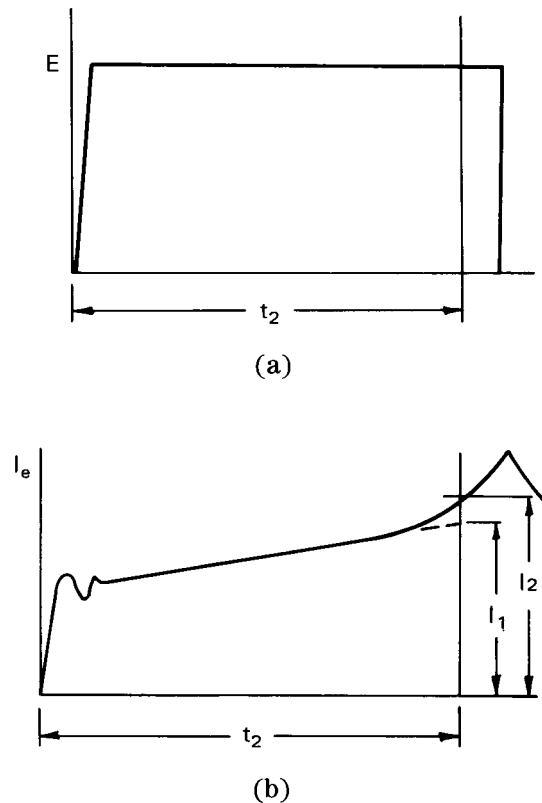

Figure 13—Departure of Exciting Current Waveform

6.6 Three Recommended Balance Test Methods (See 4.12)

The test circuit shown in Fig 14 shall be used where specified for determining balance of the transformer windings. Matched resistors of the precision type shall be used for the resistor pairs: R_1 , R_2 and R_3 , R_4 . The sums, R_1 plus R_2 and R_3 and R_4 , shall equal, within 5%, the terminating impedance specified for the associated windings. The test may be made at any frequency within the specified frequency band. Frequencies near

- 1) The low-frequency 1 dB point
- 2) The midband frequency
- 3) The high frequency 1 dB point

shall be used unless other frequencies are specified. In general, at the low frequencies the elements contributing to imbalance will usually be winding resistance and turns; in the middle frequencies, winding turns; and at the high frequencies, leakage inductances and winding capacitances.

The test is not limited to two-winding transformers, and the test circuit may be modified as required.

Balance tests are described in ANSI/IEEE Std 111-1984 [2], ANSI/IEEE Std 455-1985 [8], and [14].

6.7 Temperature Rise Test (See 4.15)

6.7.1

The load for each secondary shall be as specified. If a magnetron or other tube type load is required, proper rf loading, cooling, and shielding shall be supplied. If resistance loads are used, they shall be of the noninductive types. Specified cooling for the transformer shall be provided. Coolant temperature and flow rate shall be maintained constant (or within specified limits) for the duration of the run.

6.7.2

Specified core-reset-bias current shall be provided. A core bias isolating inductor shall be included in the heat run, when it is mounted in the same tank as the transformer.

6.7.3

The temperature-rise test shall be run at the highest specified average power for the unit. This usually occurs at a maximum voltage and maximum duty cycle.

6.7.4

The thermometer used for measuring the ambient temperature shall be protected against trivial temperature changes by means of an oil bath or other suitable method.

6.7.5

The sensor used for measuring the temperature of the core on an open unit or the case on a tanked unit shall be secured in contact with the surface to be measured by means of metal sash putty or other suitable devices.

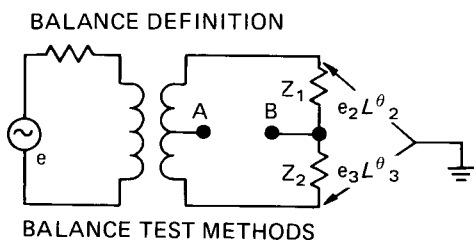

$$\text{TRANSFORMER BALANCE} = 20 \log_{10} \frac{e_2 L^{\theta}_2 - e_3 L^{\theta}_3}{e_2 L^{\theta}_2 + e_3 L^{\theta}_3} \text{ dB}$$

RESTRICTIONS:
 A, B OR BOTH MUST BE GROUNDED
 $Z_1 = R_1 + jX_1 = Z_2 = R_2 + jX_2$

GROUND CONDITIONS		TEST METHOD	TEST METHOD	BALANCE EQUATION	NOTES
TERMINAL A	TERMINAL B				
GROUND	GROUND	I	1a OR 1b, 1c	$20 \log_{10} e_2/e_1 - 20 \log_{10} e_4/e_3 + 6.02 \text{ dB}$	1, 2, 3, 4, 6, 7
FLOATING	GROUND	II	2a OR 2b, 2c	$20 \log_{10} e_2/e_1 - 20 \log_{10} e_4/e_3 + 6.02 \text{ dB}$	1, 3, 4, 6, 7
GROUND	FLOATING	III	3a OR 3b	$20 \log_{10} (e_3 L^{\theta}_3 - e_4 L^{\theta}_4)/e_2 \text{ dB}$	1, 3, 5, 6, 7

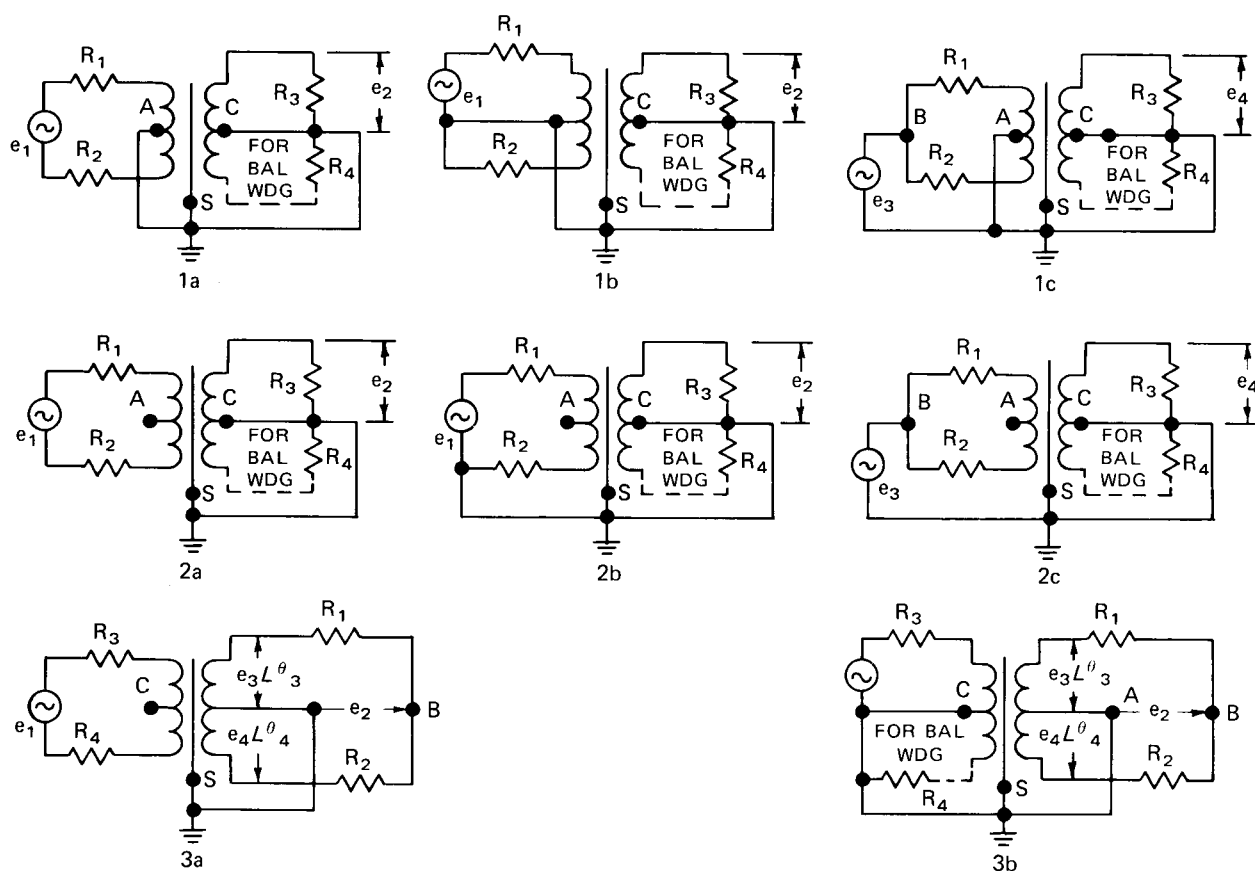

NOTES:

- 1 — The winding with terminations R_1 and R_2 is the winding under test
- 2 — Test Method I is the same as that for longitudinal balance. Transformer balance is 6.02 dB greater than longitudinal balance
- 3 — Where both windings are balanced, center tap C should be grounded or floating as required to simulate use condition
- 4 — When $e_1 = e_3$, Balance = $20 \log_{10} (2e_2/e_4)$
- 5 — Ideally $e_3 = -e_4$. Only a small approximation give Balance $\approx 20 \log_{10} (2e_3/e_4)$
- 6 — Circuits 1a, 2a, and 3a require a balanced source. When the transformer balance is 20 dB or better, an imbalanced generator may be used as in circuits 1b, 2b, and 3b with less than 1 dB error
- 7 — In all cases, $R_1 = R_2$ and $R_3 = R_4$

Figure 14—Balance Tests

6.7.6

The transformer shall be protected from air drafts and radiation from nearby warmer objects.

6.7.7

The load test shall continue until the temperature of the transformer core or case shows constancy for three successive readings at intervals of 30 min.

6.7.8

The temperature of the primary and secondary windings shall be computed by the resistance method using either of the formulas of IEEE Std 119-1974 [9]. Also see IEEE Std 389-1979 [12].

6.8 Corona (Partial Discharge) Test (See 4.14)

For corona testing, a dry, clean area, free of any condensate is essential. Since no reliable quantitative corona test method has been devised for high-voltage pulse transformers, it is recommended that the following method be used.

The test may be made during the induced voltage test with the voltage on the winding limited to the value specified for the corona measurement. If a load is used, it must be entirely corona free. The most reliable method for pulse transformers is to examine carefully the voltage waveform as monitored on the output winding. The capacitive-voltage divider and the oscilloscope used shall be wideband devices, having good response at least to 10 MHz. A corona-free capacitive voltage divider with corona-free connections shall be used. Corona will be evidenced by *fuzz* on the voltage waveform. When an open-construction type of pulse transformer is tested in an open oil tank in a darkened room, a visual observation test is also desirable to increase the chance of detecting any corona and to pinpoint its location so that corrective measures can be taken.

7. Marking

Marking shall be done in a manner that is legible and permanent on an area that is plainly visible when the transformer is mounted by normal means.

A nameplate should consist of the following items:

- 1) Manufacturer's name or identification
- 2) Product identification number
- 3) Rated pulse durations, pulse repetition frequencies, and maximum duty cycle
- 4) Rated primary and secondary pulse voltages and current
- 5) Direct-current resistance at 25 °C
- 6) Maximum filament voltage and current in bifilar windings
- 7) Diagram of windings with maximum allowable noninduced voltages
- 8) Source and load impedances

Small transformers with minimum marking area shall be marked with at least (1) and (2). All terminals shall be identified.

8. Service Conditions

Conditions for which transformers covered by this standard are suitable depend upon the application. These conditions include humidity, temperature, altitude, vibration, shock, dimensions, and flammability. Tests for these conditions should be agreed upon between user and manufacturer.

This standard does not apply to transformers when used in a wire entrance facility to an electric power station. Neither is it intended to include low-power switching-type pulse transformers. These are covered in IEEE Std 272-1970 (R 1976) [11].

9. Bibliography

[B1] BUSCH, K. J., HASLEY, A. D., and NEITZERT, Carl. *Magnetic Pulse Modulators*. Bell System Technical Journal, vol 34, Sept 1955.

[B2] GLASOE, G. N., and LEBACQZ, J. V. *Pulse Generators*. New York: McGraw Hill Book Co, Inc, 1948.

[B3] GROSSNER, N. R. *Transformers For Electronic Circuits*. New York: McGraw Hill Book Co, Inc, 1967.

[B4] LEE, Reuben. *Electronic Transformers and Circuits*. 2nd ed, New York: John Wiley and Sons, Inc, 1955.

[B5] LORD, Harold W. Pulse Transformers. *IEEE Transactions on Magnetics*, vol MAG 7, no 1, Mar 1971.

[B6] Proceedings of the IEEE, vol 61, no 3, pp 257–400, Mar 1973.

Annex A Alternate Test Methods (Informative)

(This Appendix is not a part of ANSI/IEEE Std 390-1987, IEEE Standard for Pulse Transformers, but is included for information only.)

This Appendix describes transformer test methods that are alternates to the preferred test methods of Section 6. The alternate tests may be specified when special test considerations or equipment unavailability preclude use of the preferred test methods. Precautionary notes indicate any limitations of particular test methods.

A.1 Ratio of Transformation (Turns-Ratio) Alternate Test Methods (See 4.4. and 6.1)

A.1.1 Ratio Bridge Method

The standard transformer ratio bridge used with a phase sensitive detector generally gives an accurate ratio of transformation measurement. However, transformer windings with very low inductances sometimes cannot be measured with the generally used ratio bridges (Fig A-1).

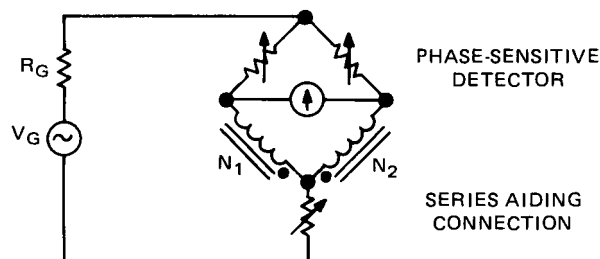

Figure A-1—Alternate Ratio Bridge Test Circuit for Measuring Ratio of Transformation

A.1.2 Single Winding Excitation and Calibrated Variable Inductor Null Method (Fig A2)

A.1.3 Ratio of Measurements of Voltage Amplitude Methods

A.1.3.1 Pulse Excitation

The ratio may be determined by applying unipolar or bipolar current or voltage pulses to one of the windings and measuring the ratio of corresponding voltage-pulse amplitudes appearing on the windings, using an oscilloscope with a high-impedance probe and an oscilloscope pulse calibrator.

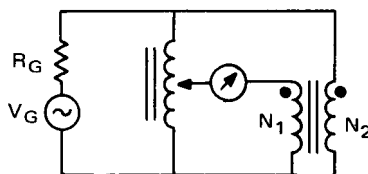

Figure A-2—Alternate Single-Winding Excitation and Calibrated Variable Inductor Null Test Circuit for Measuring Ratio of Transformation

A.1.3.2 Sinusoidal Excitation

The ratio may be determined by applying a suitable sinusoidal voltage of high frequency (for example, 500 kHz) to one of the windings and measuring the ratio of corresponding voltages appearing on the windings.

NOTE — The effect of transformer winding resistance and core loss must be carefully considered in these test methods. For multiwinding transformers, resistance and core-loss effects may be minimized by performing the test in two steps, measuring the voltages only on undriven windings.

A.2 Short-Circuit Impedance (Leakage Inductance) Alternate Test Method (See 4.1.7 and 6.2)

A.2.1

The LC meter method is an alternate transformer test method.

A.2.2 Short-Circuit Impedance (Leakage Inductance) and Effective Distributed Capacitance Test Method

This method provides an alternative test method to 6.2 and 6.3 for the determination of leakage inductance and effective distributed capacitance. It is similar to the self-resonant method of 6.3.2, except instead of an air-core inductance shunt on the primary winding, the primary winding and any auxiliary windings are short circuited and grounded. The procedure is then the same as for 6.3.2 for determining the effective distributed capacitance C_D (see A.4.1.3 NOTE).

The leakage inductance L_2 may then also be determined by noting a frequency f_o , whose reciprocal squared $1/f_o^2$, falls on the fitted straight line of the graph $1/f^2$ versus added capacitance at a maximum distance from the low-capacitance end. The inserted capacitance at this data point is added to the distributed capacitance C_D (found graphically), to make up the total capacitance C_T .

The leakage inductance is then found from the following equation:

$$L_{21} = \frac{1}{f_o^2 \cdot 4\pi^2 \cdot C_T}$$

A.3 Open-Circuit Impedance (Magnetizing Pulse Inductance and Exciting Current) Alternate Test Methods (See 4.8 and 6.3)

A.3.1 Current Ramp Applied and Voltage Pulse Observed Method

The magnetizing pulse inductance of a winding may be measured by applying a current pulse ramp of a known rate of change (di/dt) and observing the induced voltage pulse amplitude E_p . The magnetizing pulse inductance is determined from the equation

$$L_m = \frac{E_p}{di/dt}$$

A.3.2 Rectangular Voltage Pulse Applied and Tilt (Droop) of Transformed Voltage Pulse Observed Method

A.3.2.1

The tilt (droop) method of measuring magnetizing pulse inductance consists of applying a rectangular voltage pulse from a source of known resistance and measuring the percentage tilt (droop) of the transformed voltage pulse.

A.3.2.2

The magnetizing pulse inductance may be calculated from the equation

$$L_m = R_G T_d (100)/A_D$$

where

R_G	= source resistance
T_d	= duration of the applied voltage pulse
A_D	= observed tilt (droop), percentage

This equation is valid for short pulse durations where $R_G T_d L_m < 0.2$ and where $R_G \gg$ the winding resistance.

WARNING: *This measurement is highly sensitive to both the source impedance and the shape of the applied voltage pulse. The applied pulse shall have negligible tilt (droop).*

A.3.3 Sinusoidal Impedance Measurement Method

A.3.3.1

The sinusoidal open-circuit impedance measurement often closely approximates the pulse measurements for transformers with ferrite cores.

A.3.3.2

Although pulse measurements of open-circuit impedance are preferred, instrumentation limitations may require the sinusoidal measurement.

A.4 Open-Circuit Admittance (Distributed Capacitance) Alternate Test Methods (See 4.9 and 6.4)

A.4.1 Self-Resonance Method Using Q Meter Excitation.

Measurement of effective distributed capacitance with a Q meter on pulse transformers exhibiting nonlinear magnetic effects with uncontrolled excitation shall be avoided.

A.4.1.1 For Effective Distributed Capacitance ≤ 10 pF

Convenient and reasonably accurate effective distributed capacitance measurements on pulse transformers exhibiting constant open-circuit inductance over an octave range of resonant frequencies may be made on a Q meter if the resultant distributed capacitance is greater than 10 pF by the following procedure. This procedure employs the calibrated tuning capacitor of the Q meter for series resonance with the transformer inductance at two different frequencies. The first resonance is obtained with the tuning capacitor near its lower capacitance end and the frequency adjusted for peak Q indication. Let this capacitance be C_1 , and the frequency f_1 . Then a second resonance is obtained at frequency f_2 equal to exactly half of f_1 by tuning the capacitor for peak Q indication. Let this capacitance be C_2 . The effective distributed capacitance is calculated as

$$C_D = \frac{C_2 - (f_1/f_2)^2 C_1}{(f_1/f_2)^2 - 1} = \frac{C_2 - 4C_1}{3}$$

A.4.1.2 For Effective Distributed Capacitance < 10 pF

If the distributed capacitance is considerably less than 10 pF, then the following more accurate and preferred method may be employed on the Q meter. The impedance of a coil at its self-resonant frequency is resistive and usually high in value. This characteristic is employed in the measurement of the effective distributed capacitance. The frequency of the Q meter is adjusted to resonate the open-circuit inductance of the pulse transformer with the tuning capacitor set at 400 pF. This frequency and the calibrated value of the tuning capacitor is recorded as f_1 and C_1 . Reset the oscillator frequency to approximately ten times f_1 . Replace the pulse transformer with an auxiliary coil capable of resonating in the measuring circuit at this higher frequency and adjust the tuning capacitor for resonance. Connect the pulse transformer winding to the CAP terminals on the Q meter and restore resonance by adjusting the tuning capacitor. When the tuning capacitor is increased in capacitance to restore resonance, then increase the frequency and repeat until alternately connecting and disconnecting the pulse transformer to the CAP terminals changes the indicated Q but does not affect the tuning. Call this frequency the self-resonant frequency f_0 . When the tuning capacitor is decreased in the above step to restore resonance, then the frequency should be decreased until the self-resonant frequency of the pulse transformer is obtained. The effective distributed capacitance is then

$$C_D = \frac{C_1}{(f_0/f_1)^2 - 1}$$

A.4.1.3 Self-Resonance with Leakage Inductance, Using Q Meter Excitation, for Effective Distributed Capacitance ≥ 10 pF.

NOTE — This method (and A2 Method) is subject to appreciable error when the turns ratio $a < 3$.

For measurement of secondary C_D the primary and any auxiliary windings should be short circuited and grounded. The secondary winding should be connected to the Q meter terminals. Set the Q circuit capacitance at approximately 50 pF (or add whatever is required for a reasonable resonant frequency) calling this capacitance C_1 , and resonate the Q circuit by adjusting the oscillator frequency to exact resonance. Set the oscillator to a new frequency exactly half the first resonant frequency. Return the Q circuit for resonance using the Q tuning capacitor and call the new capacitor reading C_2 . The distributed capacitance C_D is then

$$C_D = \frac{C_2 - 4C_1}{3}$$

A.4.2 Ringing Method

A.4.2.1

A representation of the effective distributed capacitance referred to a winding can be obtained by pulse *shock* exciting the winding and observing the period of the ringing due to resonance of the effective distributed capacitance C_D and magnetizing inductance L_m .

$$C_D = \frac{T^2}{4 \pi^2 L_m}$$

where

T = period of the oscillation (Fig A-3)

A.4.2.2

The pulse excitation shall be equivalent to applying battery voltage across the winding by closing a switch, and then opening the switch to leave the winding open circuited during which time the period of oscillation is observed.

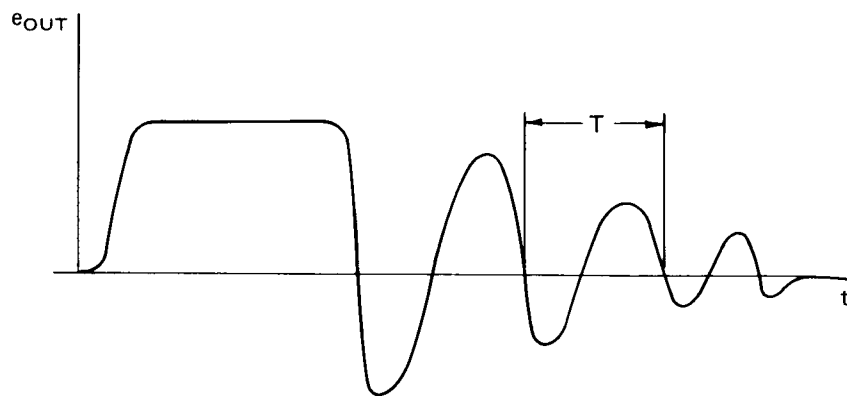

Figure A-3—Transformer Output Voltage Waveform After Pulse Shock Excitation